

# Cyclone 210

# Technical

# Manual



This document is the copyright of Money Controls Ltd and may not be reproduced in part or in total by any means, electronic or otherwise, without the written permission of Money Controls Ltd. Money Controls Ltd does not accept liability for any errors or omissions contained within this document. Money Controls Ltd shall not incur any penalties arising out of the adherence to, interpretation of, or reliance on, this standard. Money Controls Ltd will provide full support for this product when used as described within this document. Use in applications not covered or outside the scope of this document may not be supported. Money Controls Ltd. reserves the right to amend, improve or change the product referred to within this document or the document itself at any time.

## Contents

<b>1.</b>	<b>Diary of Changes .....</b>	<b>4</b>
<b>2.</b>	<b>Introduction .....</b>	<b>5</b>
2.1	Product Overview .....	5
<b>3.</b>	<b>Mechanical Features .....</b>	<b>6</b>
3.1	Variants.....	8
3.2	Coin Size Range.....	8
3.3	Coin Capacity .....	8
<b>4.</b>	<b>Installation and Removal.....</b>	<b>9</b>
4.1	Dismantling the Hopper .....	9
4.2	Securing the Base .....	9
4.3	Using the 4mm Holes .....	9
4.4	Using the Keyholes.....	9
4.5	Hopper Assembly .....	9
4.6	Coin Spillage.....	9
<b>5.</b>	<b>Mechanical Description.....</b>	<b>10</b>
5.1	Operation.....	10
5.2	Coin Routing.....	10
<b>6.</b>	<b>Electrical Interface.....</b>	<b>11</b>
6.1	Interface.....	11
6.11	Connections.....	11
6.12	Connector type .....	11
6.13	Mating connector .....	11
6.14	Pin-out Information - parallel.....	11
6.15	Pin-out Information - cctalk .....	12
6.2	Operation - Parallel.....	13
6.21	Motor Control .....	13
6.22	Motor Start-up.....	13
6.23	Coin Jam detection & clearing .....	13
6.24	Motor Protection .....	13
6.25	Coin Counting.....	14
6.26	Light Guide Blockage.....	14
6.27	Opto Testing .....	14
6.28	Count Accuracy .....	14
6.29	Level Sensing .....	14
6.3	Operation – ccTalk.....	15
6.4	Power Supply Requirements – See Section <a href="#">10.2</a> .....	15
6.41	Duty Cycle .....	15
<b>7.</b>	<b>Maintenance Schedule .....</b>	<b>16</b>
7.1	Replacing Coin Ejector Fingers .....	17
7.2	Clearing a Coin Jam .....	18
<b>8.</b>	<b>Fault Finding and Repair.....</b>	<b>19</b>
8.1	Test Equipment.....	19
8.2	Coins Fail to Un-jam .....	19
8.3	Motor Fails to Run .....	19
8.4	Over Payout of Coins.....	19
8.5	Under Payout of Coins.....	19
<b>9.</b>	<b>Field Adjustment.....</b>	<b>19</b>
9.1	Coin Exit Position.....	19
<b>10.</b>	<b>Specification .....</b>	<b>20</b>
10.1	Dimensions .....	20
10.2	Power Requirements .....	20
10.21	Count Output 1 .....	21
10.22	Count Output 2 .....	21
10.23	Control 1 Input CTI1.....	21
10.24	Test Input.....	21
10.25	Signal timings .....	21
10.3	Environment.....	22
10.31	Temperature .....	22
10.32	Humidity.....	22
10.33	Life.....	22
10.34	General.....	22
10.35	Static.....	22
10.36	Explosive Atmosphere .....	22
10.37	Audible Noise.....	22

## Figures

Figure 1: Side and Rear Coin Exit .....	6
Figure 2: Front View .....	7
Figure 3: Fixing Holes.....	7
Figure 4: Serviceable Parts .....	16
Figure 5: Screw Positions .....	17
Figure 6: Disk Bed Dis-Assembled .....	17

## Tables

Table 1: Parallel pin-outs .....	11
Table 2: ccTalk pin-outs.....	12
Table 3: Maintenance Schedule .....	16
Table 4: Electrical Specification.....	20

## 1. Diary of Changes

- Issue 2.0.....1<sup>st</sup> April 2002
- First issue in new format.
- Issue 2.1.....6<sup>th</sup> Sept 2002
- Modification to disclaimer.
- Issue 3.0.....17<sup>th</sup> June 2003
- Applied TMWP 3.2.
  - Updated information throughout.
- Issue 3.1.....24<sup>th</sup> June 2003
- Added [Figure 2: Front View](#).
  - Changed [Figure 1](#) to reflect actual product
- Issue 3.2.....30<sup>th</sup> June 2003
- Changed footer
- Issue 4.0..... 2nd January 2008
- Added ccTalk detail option

## 2. Introduction

The Cyclone 210 Coin Hopper is a modular, disc based hopper that is microprocessor driven. Its design is based on Money Controls successful Compact Hopper which has been used for over 10 years in ticketing, vending & amusement machines & has proven reliability. Cyclone 210 has incorporated extra features & security specifically aimed at gaming machine applications.

### 2.1 Product Overview

The Cyclone 210 can have up to 2 extensions fitted to the hopper bowl which gives the end user greater flexibility to change the amount of coins kept in the hopper depending on user requirements. Its compact design allows more room in the host machine for other peripherals.

The Cyclone 210 uses a rotating disc to pick up the coins & transport them to the coin exit window where a spring-loaded finger pays the coin out of the rear of the hopper in an upward direction. Simply swapping the interchangeable disc will allow the Cyclone 210 to dispense a different sized coin or token.



### 3. Mechanical Features

- Average payout rate of 5 - 6 coins per second.
- Increased Variable Capacity - Providing a large capacity making it ideal for use in gaming, vending, change, ticket and parking applications.
- Interchangeable disk enables the Cyclone Hopper to handle a greater range of tokens & coins (including coins with holes)
- Side or rear payout options.
- Auto reverse if jam detected
- Controlled by PIC based microprocessor electronics

*Figure 1: Side and Rear Coin Exit*

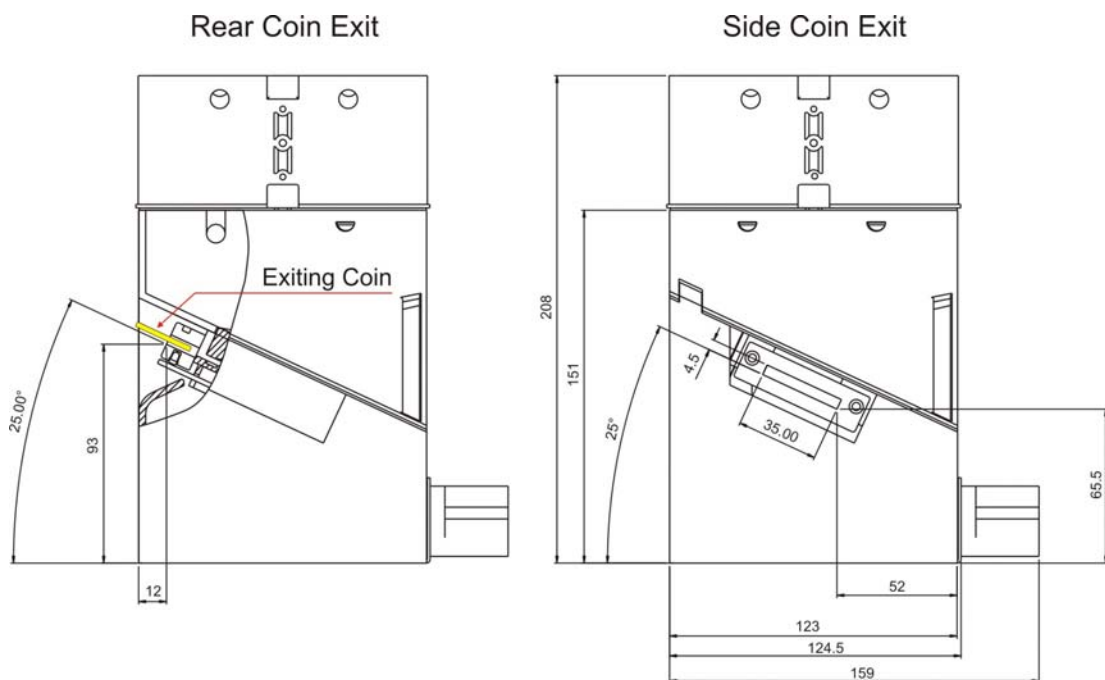

Figure 2: Front View

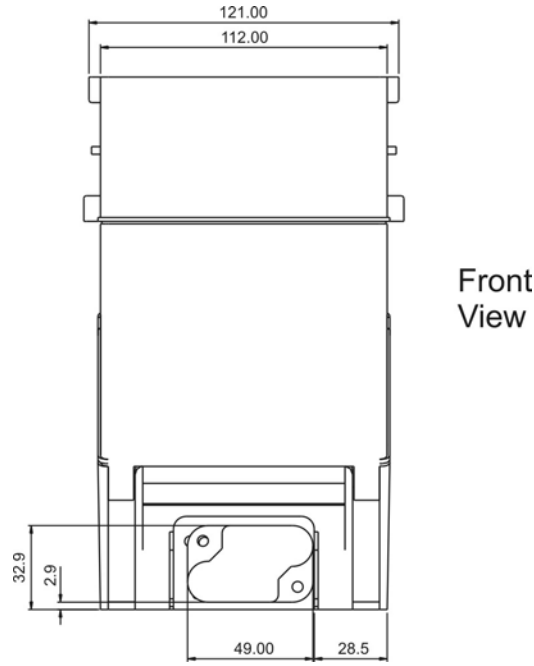
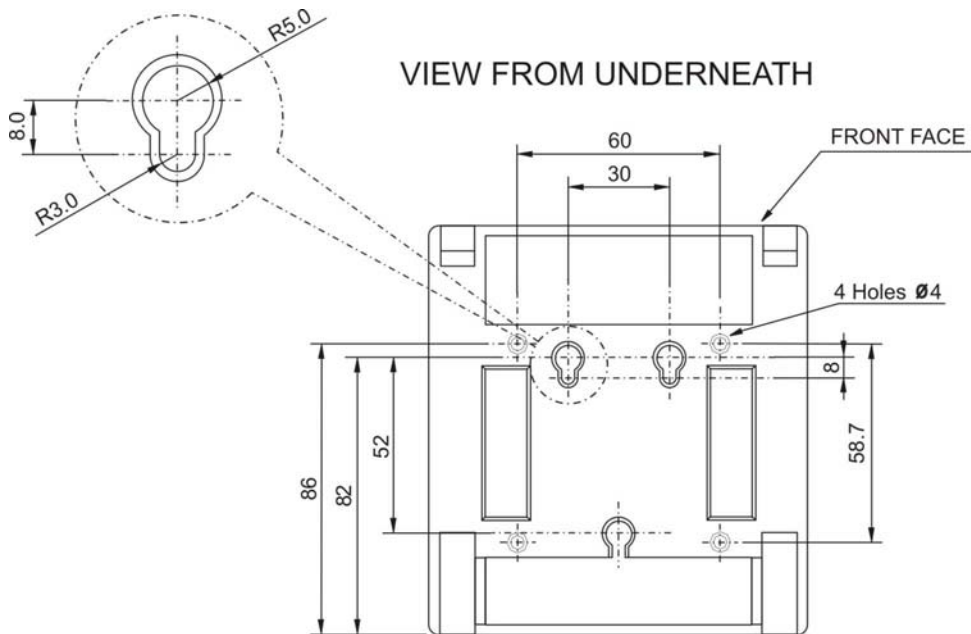

Figure 3: Fixing Holes



### 3.1 Variants

There will be several build variants, depending upon which options are selected by a customer, i.e. -

- Supply voltage - 12 or 24 Volts DC
- Level sensing - high
- Capacity - with or without bowl extensions
- Mounting position - Side or rear
- Protocol - Parallel or ccTalk (serial)

Also there will be individual disc/bed assemblies for different coin types, as there are for all disc-based hoppers.

### 3.2 Coin Size Range

<b>Diameter</b>	16 – 29.5 mm
<b>Thickness</b>	1.3 – 3.2 mm

### 3.3 Coin Capacity

	<b>€ 1.00</b>	<b>\$ 1.00 AU</b>
<b>Standard bowl</b>	265	300
<b>Bowl Extension (per extension)</b>	280	200



## 4. Installation and Removal

**WARNING:- Ensure that power has been removed from the hopper before removal.**

### 4.1 Dismantling the Hopper

1. Gently pull outwards the securing clips at the rear of each side of the base.
2. Tilt the bowl forward until it is clear of the clips.
3. Slide the bowl forward until the locating lugs, at the front of the bowl are clear of the slots at the base.
4. Unplug the level sense loom if fitted.
5. Lift the disc bed assembly out of the base.
6. Disconnect the cables from the disc / bed assembly.

### 4.2 Securing the Base

Two sets of fixing holes have been provided in the base to allow the hopper to be secured in a host machine - 4x4mm holes, and 3 keyholes. See Figure 2

### 4.3 Using the 4mm Holes

1. Drill 4 holes on the centres shown in Figure 2
2. Dismantle the Hopper as described in section 4.1
3. Place the base over the holes.
4. Fix the base into position using M3 screws.

### 4.4 Using the Keyholes

1. Drill 3 holes on the centres shown in Figure 2.
2. Insert 3 x M3.5 screws. Do not tighten.
3. Dismantle the Hopper as described in section 4.1
4. Place the base over the screws and push back as far as possible.
5. Tighten the screws to fix the base in position.

### 4.5 Hopper Assembly

1. Connect the cables to the disc / bed assembly, ensuring that they are the correct way round.
2. Lower the motor assembly into the base, ensuring that the coin exit is in the desired position (side or rear)
3. Re-connect the level sense loom, if fitted.
4. Locate the lugs, on the front of the bowl, into the slots at the front of the base.
5. Gently press down on the top of the bowl until the securing clips, on the base, click into the slots in the bowl.

### 4.6 Coin Spillage

With some coin types a coin can occasionally jump upwards out of the bowl. If this is likely to be a problem the user may fit his own version of the coin entry chute or baffle which is most suited to the application.

## **5. Mechanical Description**

### **5.1 Operation**

Each disc contains a number of holes in which the coins are held in short stacks. The disc is driven by the motor via a gear train. As the disc rotates, the coin at the bottom of one of the stacks will make contact with the ejector fingers and start to push the fingers back. Further rotation of the disc will cause the coin to start to move outwards into the exit slot. At this point the spring will be free to pull the ejector fingers forward and push the coin through the exit slot.

An optical detector is formed by an LED transmitter and photo-detectors on the PCB. The infra-red light beam is routed across the exit slot via a light guide. When a coin passes through the exit, the light beam will be broken and a coin output signal will be generated.

There are a range of discs, ejector fingers and adjuster plates available to provide optimum performance for coins within a specified range.

### **5.2 Coin Routing**

Coins are entered into the hopper through the top of the bowl, and exit through the rear or either side of the hopper, depending upon the configuration.

## 6. Electrical Interface

Failure to observe the interface requirements specified in this document may result in erroneous counts, incorrect payout rate, damage to the Hopper or cause unacceptable voltage drops affecting other units dependent upon that supply.

The supply wiring to the Hopper should be of sufficient current rating and run as a twisted pair (+24V and 0V) over a maximum length of 3 metres.

### 6.1 Interface

#### 6.11 CONNECTIONS

Connection to the hopper will be made via a 12 way AMP Metrimate connector mounted on the front of the base. The pin-out is shown below.

#### 6.12 CONNECTOR TYPE

AMP 12 way, Metrimate connector, type 211759-1 plus crimp pins type 066103-2 & 164161-3.

#### 6.13 MATING CONNECTOR

AMP 211758-1 plus crimps sockets type 066105-2

#### 6.14 PIN-OUT INFORMATION - PARALLEL

*Table 1: Parallel pin-outs*

PIN	SIGNAL
1	Count Output 1
2	CTL1 Input
3	High Level Output
4	Opto Test Input
5	N.C.
6	0 Volt Loop Back
7	Count Output 2
8	N.C.
9	N.C.
10	0 Volts DC
11	N.C.
12	24 Volts DC

**6.15 PIN-OUT INFORMATION - CCTALK***Table 2: ccTalk pin-outs*

<b>PIN</b>	<b>SIGNAL</b>
<b>1</b>	Address Select 3 – MSB
<b>2</b>	Address Select 2
<b>3</b>	Address Select 1 – LSB
<b>4</b>	N.C.
<b>5</b>	N.C.
<b>6</b>	N.C.
<b>7</b>	/Data
<b>8</b>	N.C.
<b>9</b>	N.C.
<b>10</b>	0 Volts DC
<b>11</b>	N.C.
<b>12</b>	24 Volts DC

## 6.2 Operation - Parallel

The hopper has a single operating mode. With power applied to the hopper, the motor will run and coins will be dispensed, only when the control input CTL1 is set at 0V. The input has an internal pull-up resistor, so the default state is motor braked.

### 6.21 MOTOR CONTROL

The motor is controlled by a H-bridge circuit so that it can be run in both forward and reverse directions. Four outputs from the micro-controller will set the motor into one of three conditions -

Motor Condition	Motor +ve Terminal	Motor -ve Terminal
Stop / break	0 volts	0 volts
Forward	12/24 volts	0 volts
Reverse	0 volts	12/24 volts

**All other conditions will be illegal.**

### 6.22 MOTOR START-UP

The motor will be held in the stop/brake condition until the control input is set at 0 Volts. It will then be set to run in the forward direction providing that the light guide is not blocked. The motor will be stopped again as soon as the CTL1 input is returned to its default condition or if the light guide becomes blocked for more than 120ms.

The motor will be braked for 30ms and will then run in reverse for 100ms whenever the hopper is stopped so that coins will be drawn back away from the exit window. This feature is designed to prevent coins payout out if the hopper is stopped while paying out coins and a critical event occurs in the host machine.

### 6.23 COIN JAM DETECTION & CLEARING

The current being drawn by the motor will be monitored continuously while the motor is running, in order to detect if a jam has occurred. The readings will be disregarded for the first 50ms after the motor has been switched on. This is to prevent the initial current surge from being interpreted as a jam.

When the motor is running forward and the current has exceeded the jam threshold for at least 50ms, the controller will assume that a jam has occurred. The clearing sequence will be:-

- brake the motor for 50ms.
- run motor in reverse for 200ms.
- brake the motor for 50ms.

The motor will then resume running in the forward direction, assuming that the start-up conditions are still valid.

### 6.24 MOTOR PROTECTION

A thermal cut-out will be placed in series with the motor and will prevent damage to the hopper in the event of any over-current/over power condition.

## 6.25 COIN COUNTING

The light guide, LED's and photo-transistors, mounted at the coin exit, generate beams of light across the coin path. An exiting coin will break one or more of the light beams, causing a change in state of the photo-transistor output. The light beams will be positioned so that coins with holes can be counted correctly.

The count outputs will be generated by the micro-controller. The signal from the photo-transistors will be monitored and de-bounced continually by the controller. If no coins are exiting the hopper, the output 1 transistor will be turned off and output 2 transistor will be turned on. When a valid signal is detected from the photo-transistors, the output 1 will be turned on and output 2 turned off. The output transistors will be held in their active state on for a time,  $T_{min}$ , by the controller, i.e. if the actual coin exit time is less than  $T_{min}$ , the output pulse will be increased to  $T_{min}$ . If the actual time is greater than  $T_{min}$ , the output will be reduced to  $T_{min}$ . See section 10.25 for timing details.

## 6.26 LIGHT GUIDE BLOCKAGE

If the micro-controller detects that the light guide has remained blocked for more than 120ms, the motor will be stopped, or not started. The motor will not run again until the blockage has been cleared. This is a security feature to prevent frauding during payout.

## 6.27 OPTO TESTING

An input signal will be provided to allow the user to control the LED's and simulate an exiting coin. In this way, the host machine can check that the sensor is operating correctly prior to dispensing coins.

In normal operation, the test input will be held at 0 Volts and the LED's will be turned on. Providing that the test pulse is less than 3ms, the count outputs will be toggled for the same amount of time. If the test pulse is greater than 3ms then the count outputs will generate signals whose duration will be at least  $T_{min}$ .

## 6.28 COUNT ACCURACY

**1 error in 100,000 coins**

## 6.29 LEVEL SENSING

A single level sense output is available by way of a metal plate mounted inside the bowl and a metal strip running up the outside wall of the hopper bowl/extension. The metal strip allows the user to set their desired level by changing the position of the sensor probe. One plate will be connected to 0 volts and the other will be wired to the main connector. An electrical connection between the plates, via the coins, will provide an indication of the number of coins in the hopper bowl.

A number of mounting positions are available for the high level sensor probe. Steps in coin volume are approximately 100 x Australian \$1 coins.

### **6.3 Operation – ccTalk**

Please refer to the SCH2 technical manual TSP016 SCH2 and TSP125 SCH2 ccTalk Protocol Manual.

### **6.4 Power Supply Requirements – See Section 10.2**

#### **6.41 DUTY CYCLE**

The hopper is designed for intermittent operation only and must not be permitted to run continuously for longer than 60 seconds.

**ON/OFF ratio: 1:1**

The ON period must average no more than the previous OFF time. Failure of the host machine to limit the ON time can result in overheating and degradation of the motor.

## 7. Maintenance Schedule

**WARNING:**

**Coin dust may accumulate in the Hopper during use. Inhalation of the dust should be avoided during maintenance operation. Ensure that power has been removed from the Hopper before any maintenance operations are performed.**

Table 3: Maintenance Schedule

Maintenance Schedule	
Every 50,000 to 100,000 depending on coin type.	Using a mild detergent on a damp cloth, clean the light guide. <b>No spray solvents should be used.</b>
Every 500,000 coins.	Replace ejector fingers and spring
Every 1,000,000 coins.	Replace adjuster plate
Expected product lifetime:	3 million coins with routine maintenance

Figure 4: Serviceable Parts

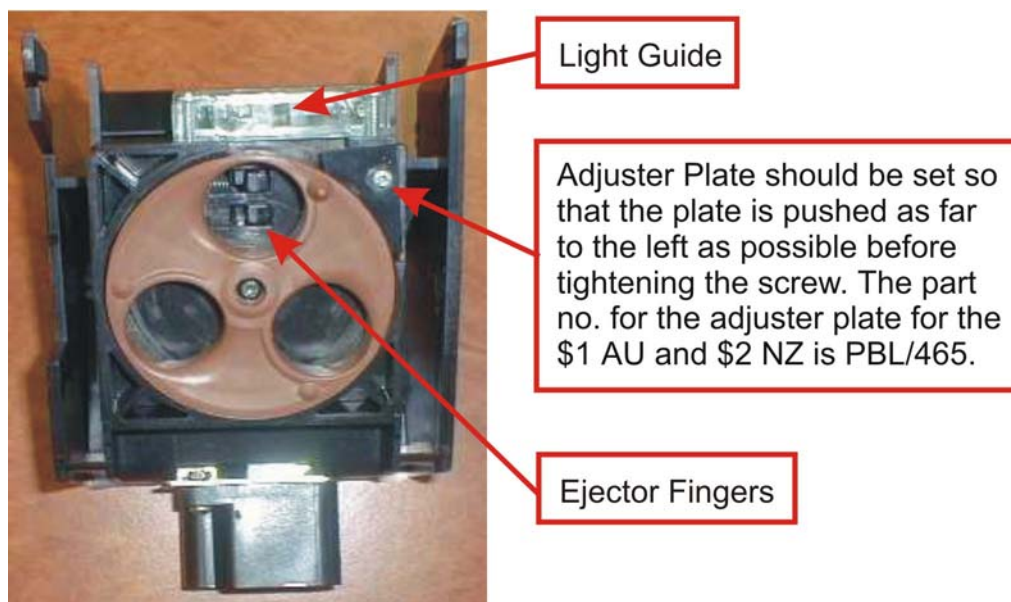



## 7.1 Replacing Coin Ejector Fingers

The ejector fingers can be replaced very easily. The first step is to take the disc motor assembly out of the hopper base. Next remove the 4 screws on the underside of the disc motor assembly (see Figure 4). Removal of these screws will allow the two PCB covers to be prised apart. Care should be taken at this point as the spring that is connected to the ejector fingers may recoil.

The part number for the \$1 Australian & \$2 New Zealand ejector finger is PBL/494.  
The part no. for the adjuster plate for the \$1 AU and \$2 NZ is PBL/465.

*Figure 5: Screw Positions*

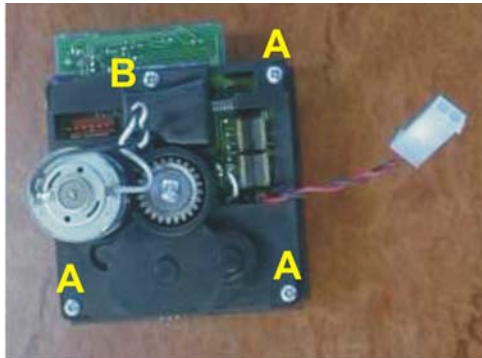

3 Screws "A" hold the PCB cover in place whilst screw "B" secures the ejector spring cover.

After replacing the ejector finger ensure that the closed loop end of the spring is located in the pin shown in Figure 5. Do not place the open end of the spring over the ejector fingers until the two halves have been brought together & at least one of the three PCB cover screws have been secured in place.

*Figure 6: Disk Bed Dis-Assembled*

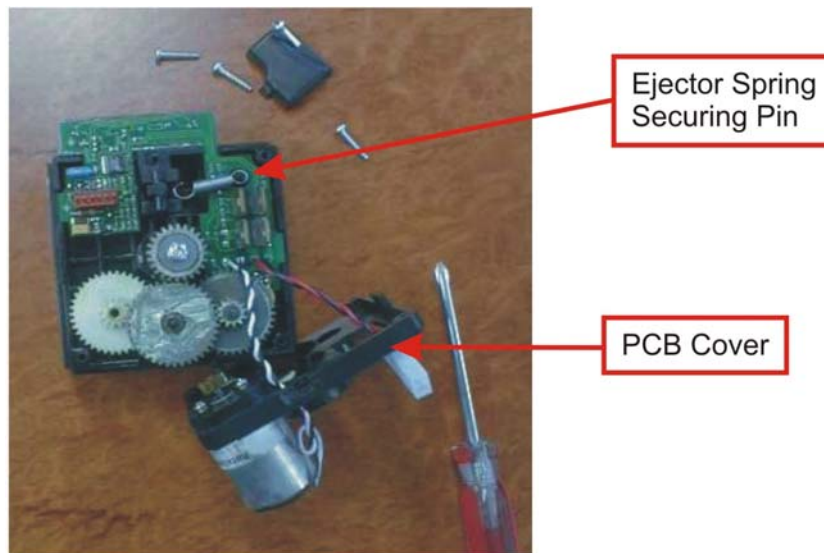

With the disc motor assembly back together use a pair of long nose pliers to place the open end of the spring onto the ejector fingers. Finally replace the ejector finger cover & screw, re-assemble the hopper & test.

## 7.2 Clearing a Coin Jam

1. Remove all coins from bowl.
2. Remove motor assembly from base as described in [4.1](#)
3. Clear the jammed coin / object by either:
  - a) Manually rotating the disc anti-clockwise then clockwise to release the object  
OR
  - b) Push the coin back in using the edge of a similar coin.

**Note:- Common cause is damaged or bent coins. Do not return these to the bowl.**

4. Remove any debris from the disc bed assembly.
5. Clean the exit window opto with a clean, dry cloth.
6. Re-assemble, as described in section [4.5](#)
7. Re-fill and test the hopper.

## 8. Fault Finding and Repair

### 8.1 Test Equipment

General purpose test equipment (meter etc) is all that is required for on-site diagnosis of Cyclone 210 failures.

### 8.2 Coins Fail to Un-jam

- Ensure coin exit is clear.
- Ensure no incorrect coins in hopper.
- Ensure no badly bent coins in hopper.

### 8.3 Motor Fails to Run

- Check supply fuse.
- Protection device tripped?
- Wait 30 seconds with supply OFF.

### 8.4 Over Payout of Coins

- Check opto area/coin exit area for dirt.
- Incorrect exit monitoring by the host machine.
- Incorrect exit output debouncing by the host machine.
- Late power down by the host machine once the correct coin output count has been reached.

### 8.5 Under Payout of Coins

- Ensure hopper contains sufficient coins.
- Incorrect exit monitoring by the host machine.
- Incorrect exit output debouncing by the host machine.
- Poor connection to hopper.

## 9. Field Adjustment

The only field adjustment possible on Cyclone 210 is:

### 9.1 Coin Exit Position

This can be altered to allow either a side or rear exit point by altering the orientation of the motor assembly within the body once the hopper bowl has been removed.

**Note:- A front exit position is not permitted when a front mounting position has been chosen.**

## 10. Specification

### 10.1 Dimensions

Height:	Standard Bowl:	150mm
	Extended Bowl:	265mm
Width:		115mm
Depth:		122mm

### 10.2 Power Requirements

**MCL recommend a 24V, 2A (12V, 5A) power supply.**

*Table 4: Electrical Specification*

Electrical Specification	12V version	24V version
Supply Voltage	+12V	+24V
Absolute Maximum	+14V	+27V
Minimum	+10V	+18V
Ripple	± 1.0V	± 1.0V
Typical Operating Current/No Load	0.5A	0.15A
Typical Operating Current/Max Load	1.1A	0.35A
Surge Current/Start Up and Reverse #	4.5A	2.0A
Opto supply current	25mA	25mA
The supply must be able to maintain V within the above limits while switching from no load to delivering *A into a non-inductive load.	*5A	*2A
Fuse size (anti-surge / delay)	2.5A	2A

**Warning:- The Hopper must not be operated outside these limits.**

# Motor start up and reversing surge current may reach 5000mA for 5ms falling to 3000mA for 30ms before settling to consumption as defined above after 200ms.

**10.21 COUNT OUTPUT 1**

Open Collector Transistor, Active Low	Condition	Maximum
	Coin present, voltage.	0.8V DC
	Coin present, current.	30 mA
	No coin, voltage.	30V DC

**10.22 COUNT OUTPUT 2**

Open Collector Transistor, Active Low	Condition	Maximum
	Coin present, voltage.	30V DC
	No coin, current.	30 mA
	No coin, voltage.	0.8V DC

**10.23 CONTROL 1 INPUT CTL1**

Open Collector Transistor driven Input	Condition	Status
	Inactive, motor stopped	Internal Pull-up to Supply Voltage via 22K resistor
	Active, motor running	Open Collector Active Low

**10.24 TEST INPUT**

Open Collector Transistor driven Input	Condition	Status
	Inactive, opto off	Internal Pull-up to Supply Voltage via 1K2 resistor
	Active, opto on	Open Collector Active Low

**10.25 SIGNAL TIMINGS**

Count output PW, $T_{min}$	40ms <b>(FIXED)</b>
Count output PW, $T_{max}$	If blocked for more than 120ms then an alarm pulse of 500ms <b>MIN</b> is generated. The output will then remain ON until the blockage is removed.
Input debounce time (CTL1, Photo-transistor)	1ms

## 10.3 Environment

### 10.31 TEMPERATURE

Storage temperature:	-20°C to +70°C
Operating temperature:	0°C to +50°C

### 10.32 HUMIDITY

Storage humidity:	10% to 95% RH non-condensing
Operating humidity:	10% to 75% RH

### 10.33 LIFE

Life: 3 millions coins, with routine maintenance  
Warranty period 1 year

### 10.34 GENERAL

Ensure coins can always move freely away from the exit.

### 10.35 STATIC

It is possible for coins paid out by the hopper to have a static charge on them. It is desirable that coins are discharged to earth before being presented to the user.

### 10.36 EXPLOSIVE ATMOSPHERE

The hopper should not be operated in an explosive atmosphere.

### 10.37 AUDIBLE NOISE

Audible noise generated by an empty hopper is typically 80-85 dBs at 1m.

This manual is intended only to assist the reader in the use of this product and therefore Money Controls shall not be liable for any loss or damage whatsoever arising from the use of any information or particulars in, or any incorrect use of the product. Money Controls reserve the right to change product specifications on any item without prior notice